

A SAR/Galileo Alerting-Beacons Detection and Parameter Preliminary Estimation Method Using Bit-frame Synchronization Pattern

Hu Nan-sai, Beijing Institute of Technology
Dong Zhi-hong, Beijing Jiaotong University
Wu Si-liang, Beijing Institute of Technology

BIOGRAPHY

Hu Nan-sai, PhD student in Department of Electronic Engineering, Beijing Institute of Technology. Major researches focus on signal processing theory and practice in navigation applications, IEEE Student Member.

Dong Zhi-hong, post doctoral in School of Electronics and Information Engineering, Beijing Jiaotong University. Major researches focus on spread spectrum signal processing.

Wu Si-liang, professor and doctoral tutor in Department of Electronic Engineering, Beijing Institute of Technology. Chief director of signal processing state key lab. Major researches are signal processing theory and practice, electronic systems and signal simulation, senior member of Chinese Institute of Electronics.

ABSTRACT

This paper deals with the signal processing techniques to be applied in the reception of distress beacons in Galileo Search and Rescue (SAR) system. In SAR/Galileo system, the ground segment receiver unit has to estimate time delays and Doppler shifts of a set of satellite-relayed replicas of the original beacon in order to compute the position where the beacon has been activated. Before located the beacon precisely, we propose a new method, using Bit-frame Synchronization Pattern, to detect distress beacons and compute parameter estimation in a reasonable range. Theoretical analysis and simulations showed that this algorithm improves detection performance and parameter estimation veracity.

INDEX TERMS: Galileo Search and Rescue (SAR)
Time of Arrival (TOA)

1 INTRODUCTION

The Galileo baseline includes a service to support Search and Rescue (SAR) by equipping its MEO satellite constellation with a dedicated SAR payload. This payload will relay the COSPAS/SARSAT 406 MHz distress beacon signals to the Ground Segment Search and Rescue Local User Terminals (MEOLUTs)^[1]. The MEOLUT is in charge of determining the location of the beacon, either by demodulating the beacon message (if the positional information is contained within the message) or by processing the times of arrival (TOA) and frequency of arrival (FOA) in the received signals through a number of satellites^{[2][3]}. Traditionally, FFT method would be used in beacon signal detection and estimation for FOA and TOA parameter. However, this algorithm is limited and depends on high signal intensity over noise. This paper proposes a new algorithm by using bit-frame synchronization pattern of beacon signals, to accomplish detection and preliminary estimation work. By using this method, FOA and TOA parameter could be pre-estimated in low CN_0 condition and offer a reasonable range for decoding and precise estimation task in next.

The remains of this paper are organized as follows. In section 2, we explain the system model. Then, in section 3, detection and preliminary estimation method is introduced using bit-frame synchronization pattern. Section 4 presents simulation result. Finally, section 5 concludes this paper.

2 SIGNAL MODEL

This section presents a brief analysis in terms of signal structure.

2.1 BASEBAND SIGNAL FORMAT

The baseband signal format of Galileo/SAR distress beacon has two different structures: short message and long message, as is shown in Figure 1.

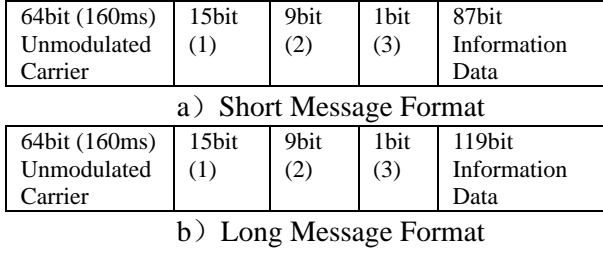

Fig1 Bacon Baseband Format

The initial 160 ms±1 percent of the transmitted signal shall consist of an unmodulated carrier at the transmitter frequency measured between the 90 percent power point and the beginning of the modulation. For short message, the final 280 ms±1 percent of the transmitted signal shall contain a 112-bit message at a bit rate of 400 bps±1 percent; For long message, the final 360 ms ±1 percent of the transmitted signal shall contain a 144-bit message at a bit rate of 400 bps±1 percent^[4].

In this final part, before the actual information data, a bit-synchronization pattern consisting of "1"s shall occupy in the first 15-bit positions and then, a frame synchronization pattern consisting of 9 bits shall occupy bit positions 16 through 24. The frame synchronization pattern in normal operation shall be 000101111.

2.2 ENCODER AND MODULATION METHOD

The data message is encoded biphas L. Then before emit, the carrier shall be phase modulated positive and negative 1.1 + 0.1 radians peak, referenced to an unmodulated carrier, as shown in Figure 2.

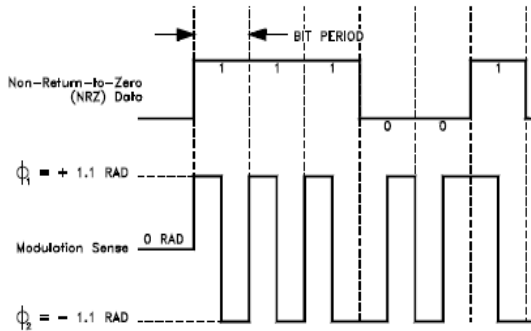

Fig2 Encoder and modulation process

2.3 SENDING SIGNAL

From above analyses, a single beacon sending signal can be expressed as:

$$x(t) = A \cos \left[2\pi f_c + F \left\{ \phi(t, T_b, t) \right\} + \phi_0 \right] \cdot \Pi \left[\frac{t - \frac{L+88}{2} T_b}{(L+88) T_b} \right] \quad (1)$$

Where

$$\Pi \left(\frac{t}{T} \right) = \begin{cases} 1 & -\frac{T}{2} \leq t \leq \frac{T}{2} \\ 0 & \text{others} \end{cases} \quad (2)$$

$$\phi(t, T_b, \tau_0) = \begin{cases} \sum_{k=1}^{L+88} 1.1b_k P_{man} [t + (89-k)T_b - \tau_0], -88T_b \leq t - \tau_0 < LT_b \\ 0 & \text{others} \end{cases} \quad (3)$$

In expressions (1), A is the amplitude of sending signal, f_c is nominal frequency of carrier, ϕ_0 is the initial phase (can be any value), L is user data coding sequence length which does not include the synchronization information (88 for short messages, 120 for long messages), T_b is one bit width, τ_0 is the Arrival Time of the end of the Frame Synchronization information, $F\{\cdot\}$ is a band pass filter operator in sending device. The message is filtered with a signal mask in order to avoid out-of-band spurious emissions or, at least, reduce them to acceptable levels.

And in expressions (3), $b_k = \pm 1$ is the k -bit synchronization and user data,

$$P_{man}(t) = \Pi \left(\frac{t - \frac{T_b}{4}}{\frac{T_b}{2}} \right) - \Pi \left(\frac{t - \frac{3T_b}{4}}{\frac{T_b}{2}} \right)$$

2.4 RECEIVING SIGNAL

After travelling through the space, a single beacon signal received by MEOLUT antenna can be expressed as:

$$x(t) = A' \cos \left[2\pi (f_c t + f_d t) + F \left\{ \phi(t, T_b, \tau_0) \right\} + \phi_0 \right] \cdot \Pi \left[\frac{t - \frac{88+L}{2} T_b - \tau_0}{(88+L) T_b} \right] + w(t) \quad (4)$$

Different to sending signal, A' is the amplitude of receive signal, f_d is the carrier frequency change by Doppler effects, τ_0 is the arrival time of the end of the frame synchronization information. $w(t)$ is additive noise and all other disturbing terms, like multipath of each signal or interferences. In our study use AWGN without loss of generality.

After demodulation by f_c , receive signal becomes:

$$r(t) = s(t) + w(t) = A' \exp \left[j2\pi f_d t + jF \left\{ \phi(t, T_b, \tau_0) \right\} + j\phi_0 \right] \cdot \Pi \left[\frac{t - \frac{88+L}{2} T_b - \tau_0}{(88+L) T_b} \right] + w(t) \quad (5)$$

Essentially, single beacon signal processing is a signal detection and estimation mission with unknown parameters $A_0 = A \exp(j\phi_0)$, f_d , T_b , τ_0 and $\{b_k; k=25, 26, \dots, L\}$.

These parameters, $\{b_k; k=25, 26, \dots, L\}$ is the actual information data part in baseband and could be gained by decoding, however, more importantly, in the goals of finding where the distress beacon is, signal processing need to estimate the offset carrier frequency (f_d), the time of the beacon signal arrival (τ_0) and the one bit width (T_b) in the beacon signal. From these three parameters, the frequency of

arrival, defined as the frequency at time of the Frame Synchronization ending, also can be calculated. Undoubtedly, time of arrival and frequency of arrival is major researched because they respectively indicated the distance and speed of beacon.

3 DETECTION AND PARAMETER PRELIMINARY ESTIMATION METHOD USING BIT-FRAME SYNCHRONIZATION PATTERN

3.1 DETECTION AND PRELIMINARY ESTIMATION BASED ON FFT

FFT method is base on following consideration: Because the beacon signal is modulated on carrier and presences unmodulation carrier part, so f_d in the beacon can be estimated by FFT operation. On the other hand, compared with else modulation part, unmodulation carrier part has maximum energy, so this feather could be use to estimate the arrival timing N_0 . This is the classic sine signal detection and estimation problem in range, phase, frequency and time of arrival are unknown.

The signal beacon can be detected by calculate FFT of receive signal and compare whether the maximum result of FFT is exceed the threshold. When detected the beacon is arrived, by calculate and compare different time's segments of receive signal, find the maximal FFT result of different time's segments to have a ML estimations of time of arrival \tilde{N}_0 and find the maximal FFT result in this segment to have a estimations of frequency of arrival \tilde{f}_d .

By make use of FFT operation, this method is easy implementation and have good computational efficiency. Through the carrier energy maximum, however, to position the time of signal arrival will have a poor performance on estimation variance. And also because only used the carrier frequency information, so any narrow band frequency interference entered receive signal could cause FFT result over the threshold and cause a wrong detection.

3.2 DETECTION AND ESTIMATION BY BIT-FRAME SYNCHRONIZATION PATTERN

Noting that the beacon signal can be divided into 3 segments: unmodulation carrier part, bit-frame synchronization part and information data part, we can use this feature to break down the mission into several sub-easy problems, by solving these sub problems, to get a sub-optimal solution.

The unmodulation carrier segment, bit-frame synchronization segment and information data segment can be described as follows:

$$s_T(t) = A \exp[j2\pi f_d t + j\phi_0] \prod \left(\frac{t + 56T_b - \tau_0}{64T_b} \right) \quad (6)$$

$$s_P(t) = A \exp[j2\pi f_d t + jF\{\phi(t, T_b, \tau_0)\} + j\phi_0] \prod \left(\frac{t + 12T_b - \tau_0}{24T_b} \right) \quad (7)$$

$$s_D(t) = A \exp[j2\pi f_d t + jF\{\phi(t, T_b, \tau_0)\} + j\phi_0] \prod \left(\frac{t - \frac{LT_b}{2} - \tau_0}{LT_b} \right) \quad (8)$$

First, with the consideration of efficiency and complication in calculating, we could also use FFT operation to have a ML estimations of f_d and N_0 by maximum FFT result value, and recorded as \tilde{f}_{d0} and \tilde{N}_{00} .

Then, as any narrow band frequency interference could cause FFT result over the threshold, it can not be reached conclusions that the beacon signal is arrived by only use FFT detection. Noted that the beacon signals will have bit-frame synchronization segment after the unmodulation carrier segment, therefore, beacon signal is existed on establishment of following conditions:

$$H_0 : r(n) = \begin{cases} w(n) & n=0,1,\dots,N_0-1 \\ A_0^* S_{TP}(n; f_d, T_b, \tau_0) + w(n) & n=N_0, N_0+1, \dots, N_0+M_0-1 \\ d_1(n) + w(n) & n=N_0+M_0, N_0+M_0+1, \dots, N-1 \end{cases} \quad (9)$$

Where

$$M_0 = \left\lceil \frac{88T_b}{T_s} \right\rceil$$

$$-\Delta f_{d0} \leq f_d \leq +\Delta f_{d0},$$

$$2.475ms \leq T_b \leq 2.525ms,$$

$$t_0 + (\tilde{N}_{00} - \Delta N_{00})T_s + 88T_b \leq \tau_0 \leq t_0 + (\tilde{N}_{00} + \Delta N_{00})T_s + 88T_b$$

$$S_{TP}(n; f_d, T_b, \tau_0) = \exp[j2\pi f_d n T_s] \prod \left(\frac{t_0 + n T_s - \tau_0 + 56T_b}{64T_b} \right)$$

$$+ \exp \left[j2\pi f_d n T_s + j \sum_{k=1}^{24} 1.1 a_k D_{man}(t_0 + n T_s - \tau_0 - (k-25)T_b) \right]$$

$$\cdot \prod \left(\frac{t_0 + n T_s - \tau_0 + 12T_b}{24T_b} \right)$$

Where Δf_{d0} and ΔN_{00} are maximum estimation error for f_d and N_0 by FFT detection respectively.

To determine whether this conditions is true, similar to determine whether the following conditions is true:

$$H_1 : r(n) = \begin{cases} w(n) & n=0,1,\dots,N_0-1 \\ A_0^* S_{TP}(n; f_d, T_b, \tau_0) + w(n) & n=N_0, N_0+1, \dots, N_0+M_0-1 \\ w(n) & n=N_0+M_0, N_0+M_0+1, \dots, N-1 \end{cases} \quad (10)$$

As

$$\begin{aligned}
& p(\mathbf{r}; A'_0, f_d, T_b, \tau_0, H_1) \\
&= \prod_{n=0}^{N_0-1} \frac{1}{\pi\sigma^2} \exp\left[-\frac{1}{\sigma^2}|r(n)|^2\right] \\
&\cdot \prod_{n=N_0}^{N_0+M_0-1} \frac{1}{\pi\sigma^2} \exp\left[-\frac{1}{\sigma^2}|r(n)-A'_0 s_{TP}(n; f_d, T_b, \tau_0)|^2\right] \\
&\cdot \prod_{n=N_0+M_0}^{N-1} \frac{1}{\pi\sigma^2} \exp\left[-\frac{1}{\sigma^2}|r(n)|^2\right] \\
&= \prod_{n=0}^{N-1} \frac{1}{\pi\sigma^2} \exp\left[-\frac{1}{\sigma^2}|r(n)|^2\right] \\
&\cdot \prod_{n=N_0}^{N_0+M_0-1} \exp\left\{-\frac{1}{\sigma^2}[-r(n)A'_0 s_{TP}^*(n; f_d, T_b, \tau_0) \right. \\
&\quad \left. -r^*(n)A'_0 s_{TP}(n; f_d, T_b, \tau_0) + |A'_0|^2]\right\} \tag{11}
\end{aligned}$$

So, the ML estimates of A'_0, f_d, T_b, τ_0 is equivalent to solve the following non-linear optimization problem:

$$\begin{aligned}
\tilde{A}'_{01}, \tilde{f}_{d1}, \tilde{T}_{b1}, \tilde{\tau}_{01} = \arg \min_{A'_0, f_d, T_b, \tau_0} & \sum_{n=N_0}^{N_0+M_0-1} [-r(n)A'_0 s_{TP}^*(n; f_d, T_b, \tau_0) \\
& -r^*(n)A'_0 s_{TP}(n; f_d, T_b, \tau_0) + |A'_0|^2] \tag{12}
\end{aligned}$$

Seeking partial derivatives for A'_0 , and let it equals to 0:

$$\sum_{n=N_0}^{N_0+M_0-1} [-r^*(n)s_{TP}(n; f_d, T_b, \tau_0) + A'_0] = 0 \tag{13}$$

$$A'_0 = \frac{1}{M_0} \sum_{n=N_0}^{N_0+M_0-1} r(n)s_{TP}^*(n; f_d, T_b, \tau_0) \tag{14}$$

Then take (14) into (12), the ML estimation of f_d, T_b, τ_0 will be:

$$\tilde{f}_{d1}, \tilde{T}_{b1}, \tilde{\tau}_{01} = \arg \max_{f_d, T_b, \tau_0} \frac{1}{M_0} \left| \sum_{n=N_0}^{N_0+M_0-1} r(n)s_{TP}^*(n; f_d, T_b, \tau_0) \right|^2 \tag{15}$$

Return this result to (12), will get the ML estimates of A'_0 :

$$\tilde{A}'_{01} = \frac{1}{M_0} \sum_{n=N_0}^{N_0+M_0-1} r(n)s_{TP}^*(n; \tilde{f}_{d1}, \tilde{T}_{b1}, \tilde{\tau}_{01}) \tag{16}$$

From expression (11),

$$\begin{aligned}
\frac{p(\mathbf{r}; A'_0, f_d, T_b, \tau_0, H_0)}{p(\mathbf{r}; H_0)} &= \prod_{n=N_0}^{N_0+M_0-1} \exp\left\{-\frac{1}{\sigma^2}[-r(n)A'_0 s_{TP}^*(n; f_d, T_b, \tau_0) \right. \\
&\quad \left. -r^*(n)A'_0 s_{TP}(n; f_d, T_b, \tau_0) + |A'_0|^2]\right\} \tag{17}
\end{aligned}$$

Same as:

$$\frac{p(\mathbf{r}; \tilde{A}'_{01}, \tilde{f}_{d1}, \tilde{T}_{b1}, \tilde{\tau}_{01}, H_0)}{p(\mathbf{r}; H_0)} = \exp\left\{\frac{1}{\sigma^2} \frac{1}{M_0} \left| \sum_{n=N_0}^{N_0+M_0-1} r(n)s_{TP}^*(n; \tilde{f}_{d1}, \tilde{T}_{b1}, \tilde{\tau}_{01}) \right|^2\right\} \tag{18}$$

The GLRT judgment for beacon signal is existed could be described as:

$$\exp\left\{\frac{1}{\sigma^2} \frac{1}{M_0} \left| \sum_{n=N_0}^{N_0+M_0-1} r(n)s_{TP}^*(n; \tilde{f}_{d1}, \tilde{T}_{b1}, \tilde{\tau}_{01}) \right|^2\right\} > \gamma \tag{19}$$

Clearly, using unmodulation carrier segment and bit-frame synchronization segment, beacon signal can be detected under GLRT rule, and also acquired ML estimation of f_d, T_b, τ_0 . Recorded as

$$J(f_d, T_b, \tau_0) = \frac{1}{M_0} \left| \sum_{n=N_0}^{N_0+M_0-1} r(n)s_{TP}^*(n; f_d, T_b, \tau_0) \right|^2 \tag{20}$$

Calculated this function by different f_d, T_b, τ_0 values, judge the beacon signal is existed when J is over the threshold. Also in this process, ML estimate of f_d, T_b, τ_0 could be obtained from maximum value of J . As mentioned above, using the estimation result from FFT detection, the range of calculations could be limit in range. f_d limited in $[-\Delta f_{d0}, +\Delta f_{d0}]$; τ_0 limited in $[t_0 + (\tilde{N}_{00} - \Delta N_{00})T_s + 88T_b, t_0 + (\tilde{N}_{00} + \Delta N_{00})T_s + 88T_b]$; by the beacon norms, T_b could be limited in 400 bps \pm 1 percent, namely [2.475 ms, 2.525ms].

It must be pointed out, we can calculate gravity function of J instead of directly use maximum value of J in ML estimate process of f_d, T_b, τ_0 , this will breakthrough the restrictions by the search step for a better veracity.

4 SIMULATION RESULTS

In accordance with the corresponding norms of beacon signal, producing a digital base-band beacon signal, the sampling rate is 200 KHz, information data are 0,1 code generated randomly, signal format is short message format, data rate is 400 bps, and through 4 KHz bandwidth shaping filter(256 order band pass FIR filter) before modulation to the carrier frequency after. Set Doppler frequency as 39 kHz, Doppler rate as 0.7 Hz / s for received signal, randomly adding AWGN noise by setting receiver $CN_0 = 34.8\text{dBHz}$, 45.3dBHz and 55.4dBHz . Using MATLAB to observe the TOA and FOA estimation error by 1000 times simulation, the results shown in Figure 3, 4.

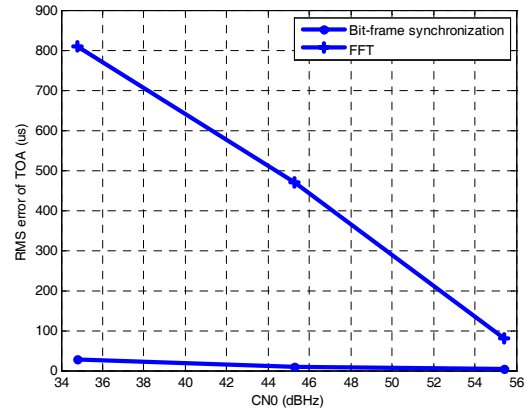

Fig3 Estimation result of τ_0

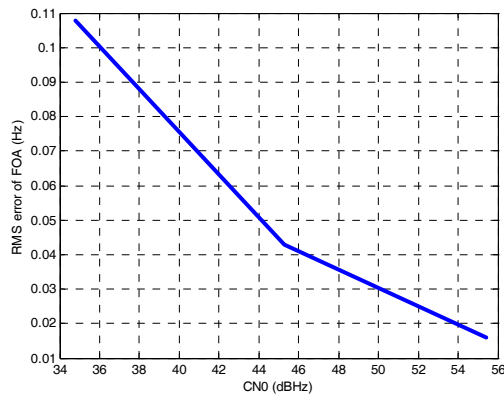

Fig4 Estimation result of f_d

From figure 3, we can see using the algorithm based on bit-frame synchronization segment can detected and estimated τ_0 in a more general range under low CN_0 situation, compared with FFT algorithm. And from shown in figure 4, this method also can get a good result in f_d estimation. When CN_0 of receiver equals 34.8 dBHz, RMS error of Doppler shift is nearly 0.1Hz; RMS error of TOA is 28.67 us.

5 CONCLUSIONS

This paper proposes an algorithm use of Bit-frame synchronization pattern in the distress signal detection and parameter estimation of the COSPAS/SARSAT Search and Rescue system. The main contributions are decreased estimation variance of parameters in pre-estimation processing, and also overcome the problems in FFT estimation, such as the single frequency interference in the system.

Simulation results show the performance of such algorithm has a reasonable computation effort while signal masked in high noise level. This is useful and helpful for decoding and precise beacon locating in next procedures.

ACKNOWLEDGEMENTS

The authors would like to acknowledge and thank by The National Remote Sensing Centre of China, Space Star Technology Co., Ltd and The European Space Agency, for the support provided in the execution of the activities discussed in this paper.

REFERENCES

- [1] National Remote Sensing Centre China, "Implementation of Galileo MEOLUT", 2005-05
- [2] P. Closas G´omez, C. Fern´andez Prades, J.A. Fern´andez-Rubio, Gonzalo Seco Granados, and Igor Stojkovic, "Design of Local User Terminals for

Search and Rescue systems with MEO satellites," in Proceedings NAVITEC, Noordwijk, The Netherlands, December 2004, ESA/ESTEC.

[3] Kayton, M., and Freid, W. R. "Avionics Navigation Systems", New York: Wiley, 1969.

[4] Cospas-Sarsat Council, "Specification for Cospas-Sarsat 406 MHz distress beacons," Tech. Rep. T.001, COSPAS-SARSAT, October 1999, Available at

<http://www.cospasarsat.org/download/t1oct28.pdf>.